

The Zebbrace Standard is a larger and deeper, attaché-sized case that is perfect for a portable mixer, drum machine, wireless microphone system, location recording set-up, lap-top computer and just about anything else that can benefit from impact and dust protection.

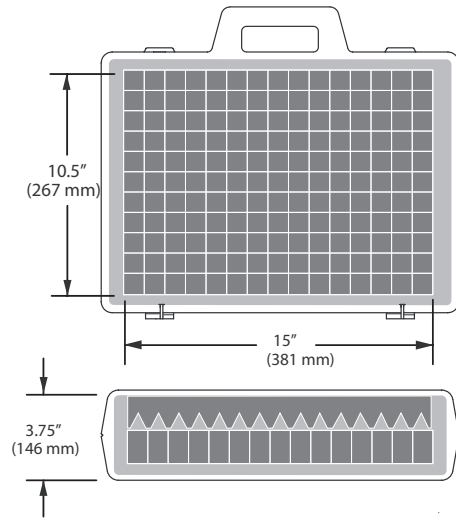
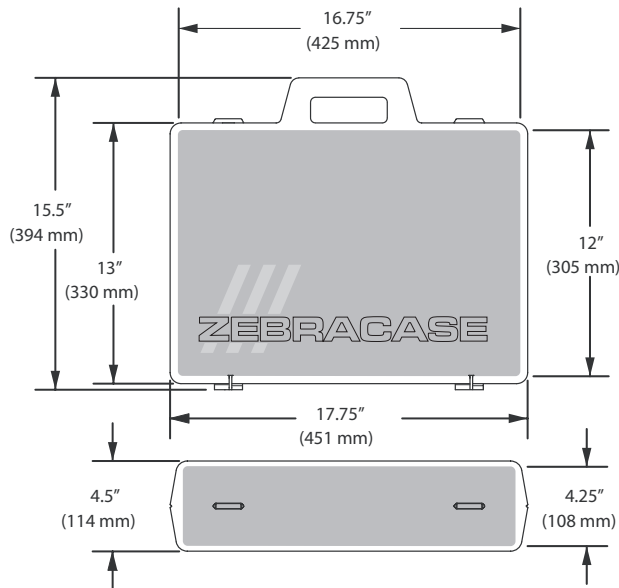

 = Interior dimensions

 = Foam cradled dimensions

SPECIFICATIONS	Z9 Micro Order# Z100 0009
Case material	Polypropylene
Nominal shell thickness	.225"
Latches	Nylon
Mating joint type	Tongue & groove
Hinge pins	Stainless steel
Pick & protect foam	1.7 lb polyurethane
Temperate rating <sup>(1)</sup> in storage	0°F (-18°C) to +120° F (+50°C)
Temperate rating <sup>(2)</sup> transport	10°F (-12°C) to +105° F (+40°C)
Temperate rating <sup>(3)</sup> drop	32°F (0°C) to +105° F (+40°C)
Standard Color	Black
Warranty:	3 years *

Temperature ratings: Zebbrace is well suited for term storage under severe<sup>(1)</sup> conditions. These case are designed to be used during normal ambient temperatures<sup>(2)</sup> and are tested above freezing<sup>(3)</sup> where plastics when left in sever cold can crack if subjected to abuse. Zebbracases are desigend to work under these conditions and guaranteed to do so for 3 years.\*See warranty information on the web site for complete details